



# INLINE DRIVE IU-XL SERIES Ratchet Wrench





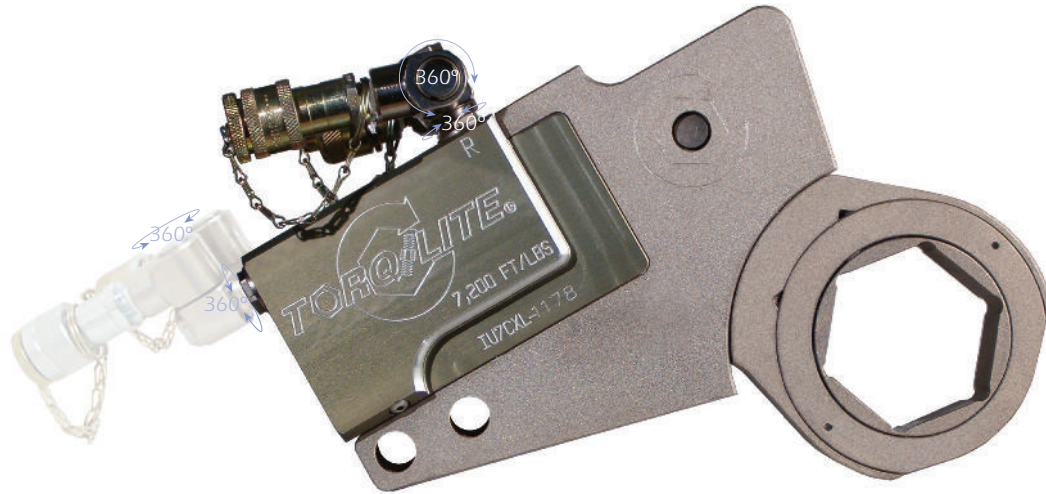

ISO 9001 Registered

For Immediate Assistance in the U.S. Call: 877-777-4046

For Assistance Outside the U.S. Call: 713-983-7171



Inline ratcheting wrenches require minimum clearance while applying torque on the same plane as the nut, providing a marked improvement over square drive socket wrenches. Our patented design breakthrough reduced the overall dimensions of the inline ratcheting head allowing it to fit almost every application. Our IU-XL Series tool capacities range from 100 to 50,000 foot pounds of torque using a 10,000 p.s.i. hydraulic pump. **"Extra light, dependable, and fits where others can not"**

-  **Inline Drive** - Standard fractional head sizes from 3/4" to 7-1/4" and 19mm to 185mm nuts across the flats. Special sizes available upon request.
-  **Precision Machined** - increases accuracy, durability and repeatability.
-  **Unibody** - Eliminates "Pinch Points".
-  **360° Swivel Fittings (Patented)** - Allow hose movement without hose binding. Stainless steel with fewer moving parts - a great improvement over competitors' delicate design. (Dual plane swivel fittings shown on wrench above.)
-  **Slotted Piston Rod** - Maintains 90° relationship between piston rod and nut. Increases accuracy. Reduces number of moving parts.
-  **Cylinder** - Made of TL T-6 durable, high-strength, lightweight aircraft alloy with the same sturdy, dependable and accurate design (as steel cylinder).
-  **Fast Head Exchange** - Spring retaining-clip allows for quick and simple changing of various head sizes.
-  **Reaction Pad** - Reacts against adjacent nut. No reaction member necessary.
-  **Multi-Axis Porting System** - The Torq/Lite® IU-XL Series tools are the first and only system that allows the swivels to be manually relocated from the top of the tool to the back of the tool (or vice versa) using only simple hand tools!
-  **Drive Pin Design (Patented)** - Reduces overall dimensions of hex head including a thinner "nose" radius. Fits more applications, including all 57 A.P.I. flanges.
-  **Coated** - All exposed parts to resist corrosion.
-  **Light/Ergonomic** - Reduces operator fatigue.
-  **Calibrated** - Every tool is tested and calibrated to  $\pm 0.03$  accuracy, traceable to N.I.S.T.
-  **Warranty** - Torq/Lite® SU-XL Series wrenches come with a 3 Year – 2 Tier warranty, that is the best standard warranty on the market today! We stand behind our wrenches like no other!



[www.torqlite.com](http://www.torqlite.com)



# INLINE DRIVE IU-XL SERIES Ratchet Wrench

ISO 9001 Registered

For Immediate Assistance in the U.S. Call: 877-777-4046

For Assistance Outside the U.S. Call: 713-983-7171

## Ratchet Wrench

## (Available Upon Request) Accessories

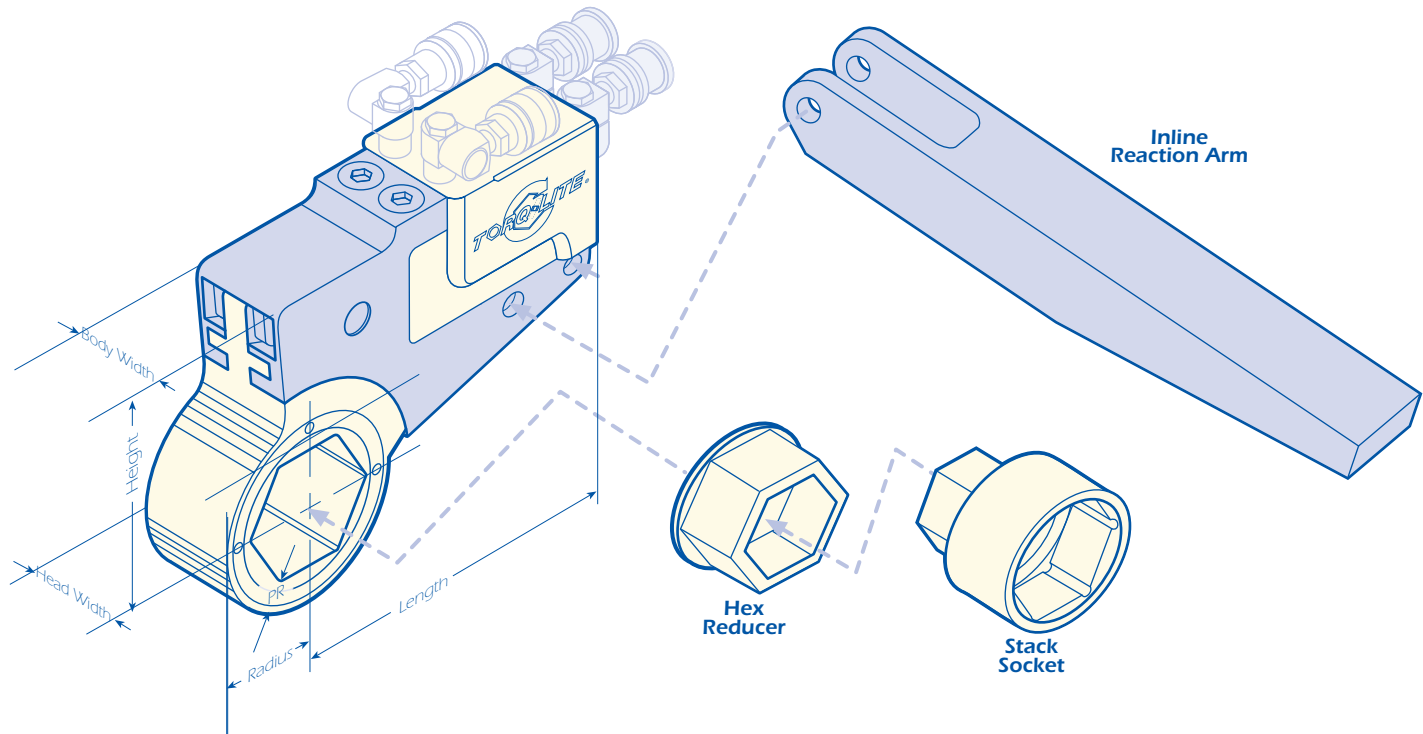

IU-XL Series	Min. -Max. Ft. Lbs. @ 10,000 psi (+/- 3%)	Min. -Max. Nm @ 700 bar (+/- 3%)	Length	Height Width	Body Width	Head	Range with Head	Weight
<b>IU-1XL</b>	117/1,294	159/1,754	6.250"	4.000"	1.100"	.950"	3/4" - 2"	7.25 lbs.
<b>IU-3XL</b>	294/3,074	399/4,168	7.000"	5.750"	1.450"	1.075" or 1.200"	1-1/4" - 2-15/16"	9.25 lbs.
<b>IU-7XL</b>	667/6899	904/9,354	9.250"	6.250"	1.500"	1.500"	2" - 3-7/8"	14.00 lbs.
<b>IU-10XL</b>	990/9,900	1,342/13,423	9.750"	8.000"	1.950"	1.950"	2-3/8" - 4-1/4"	24.50 lbs.
<b>IU-17XL</b>	1,513/15,951	2,051/21,627	11.250"	9.250"	1.950"	2.450"	2-3/4" - 5-3/8"	42.00 lbs.
<b>IU-25XL</b>	2,260/23,620	3,064/32,024	11.250"	9.250"	2.900"	2.950"	3-1/2" - 5-3/4"	57.00 lbs.
<b>IU-50XL<sup>§</sup></b>	3,475/44,785	4,711/60,720	15.375"	10.500"	2.900"	2.950"	4-5/8" - 7-1/4"	85.00 lbs.

\* 1-1/4" to 2" Heads † 2-3/16" to 2-15/16" Heads § Steel Cylinders Only

IU-1XL Heads			IU-3XL Heads			IU-7XL Heads			IU-10XL Heads			IU-17XL Heads			IU-25XL Heads			IU-50XL Heads		
ATF	Radius	P/R	ATF	Radius	P/R	ATF	Radius	P/R	ATF	Radius	P/R	ATF	Radius	P/R	ATF	Radius	P/R	ATF	Radius	P/R
3/4"	1.07"	0.41"	1-1/4"	1.38"	0.35"	2"	1.80"	0.47"	2-3/8"	2.02"	0.45"	2-3/4"	2.50"	0.90"	3-1/2"	2.90"	0.87"	4-5/8"	3.92"	1.25"
1-1/16"	1.18"	0.34"	1-7/16"	1.46"	0.35"	2-3/16"	1.88"	0.47"	2-9/16"	2.15"	0.47"	2-15/16"	2.62"	0.90"	3-7/8"	3.18"	0.95"	5"	4.13"	1.25"
1-1/4"	1.29"	0.34"	1-5/8"	1.57"	0.35"	2-3/8"	2.02"	0.47"	2-3/4"	2.40"	0.55"	3-1/8"	2.70"	0.90"	4-1/4"	3.35"	0.90"	5-3/8"	4.35"	1.25"
1-7/16"	1.40"	0.34"	1-13/16"	1.70"	0.40"	2-9/16"	2.15"	0.47"	2-15/16"	2.55"	0.50"	3-1/2"	2.90"	0.90"	4-5/8"	3.58"	0.90"	5-3/4"	4.57"	1.25"
1-5/8"	1.51"	0.34"	1-7/8"	1.79"	0.46"	2-3/4"	2.40"	0.55"	3-1/8"	2.62"	0.55"	3-7/8"	3.18"	0.95"	5"	3.85"	0.96"	6-1/8"	4.78"	1.25"
1-13/16"	1.61"	0.34"	2"	1.79"	0.40"	2-15/16"	2.55"	0.50"	3-1/2"	2.85"	0.85"	4-1/4"	3.35"	0.96"	5-3/8"	4.10"	1.00"	6-1/2"	5.00"	1.25"
2"	1.72"	0.34"	2-3/16"	1.90"	0.40"	3-1/8"	2.62"	0.55"	3-7/8"	3.07"	0.85"	4-5/8"	3.58"	0.96"	5-3/4"	4.32"	1.02"	6-7/8"	5.22"	1.25"
			2-3/8"	1.97"	0.40"	3-1/2"	2.85"	0.63"	4-1/4"	3.26"	0.85"	5"	3.90"	1.00"				7-1/4"	5.43"	1.25"
			2-9/16"	2.12"	0.46"	3-7/8"	3.04"	0.60"				5-3/8"	4.10"	1.00"						
			2-3/4"	2.24"	0.46"															
			2-15/16"	2.36"	0.46"															

[www.torqlite.com](http://www.torqlite.com)



# INLINE DRIVE IU-XL SERIES Ratchet Wrench

ISO 9001 Registered

For Immediate Assistance in the U.S. Call: 877-777-4046

For Assistance Outside the U.S. Call: 713-983-7171

## Ratchet Wrench

## (Available Upon Request) Accessories

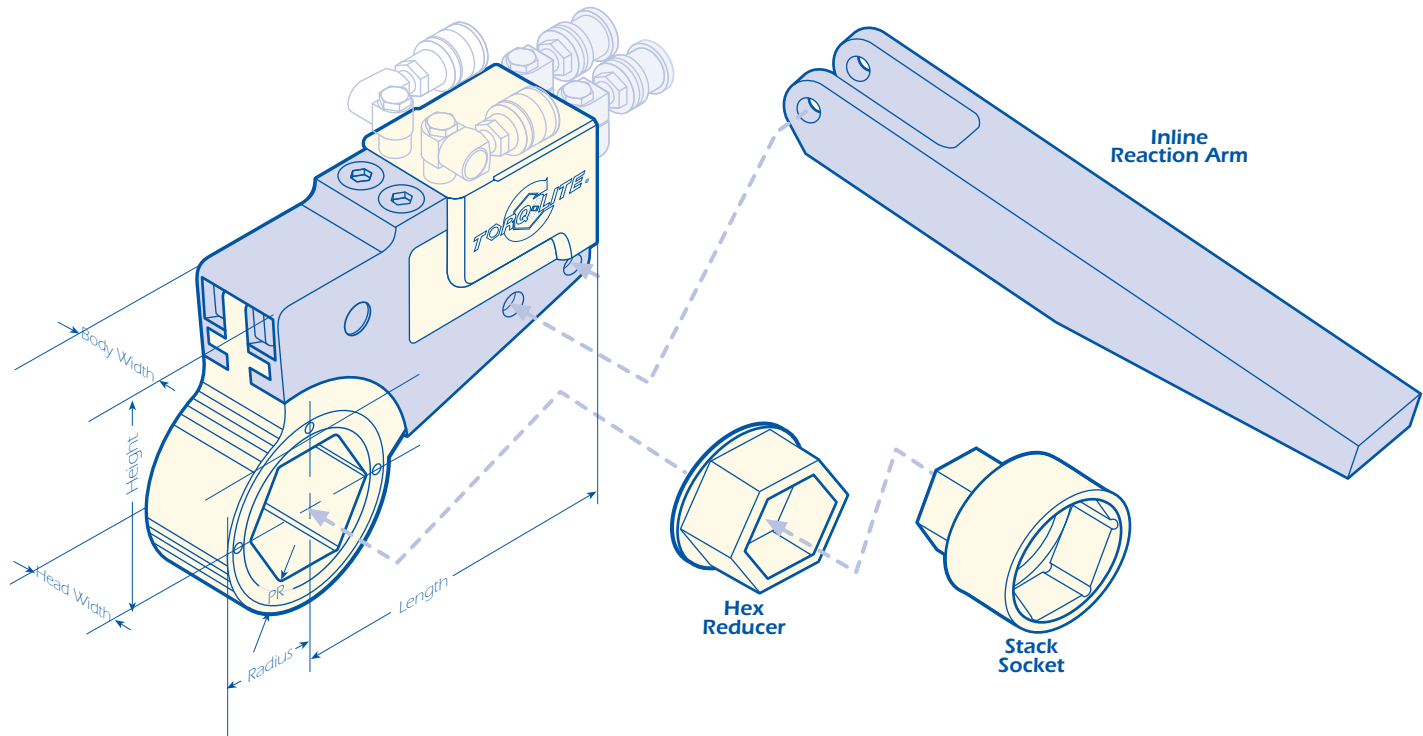

IU-XL Series	Min. - Max. Nm @ 700 bar (± 3%)	Min. - Max. Ft. Lbs. @ 10,000 psi (± 3%)	Length	Height	Body Width	Head Width	Range	Weight with Head
<b>IU-1XL</b>	159/1,754	117/1,294	159mm	102mm	28mm	24mm	19mm - 51mm	3.29 kg.
<b>IU-3XL</b>	399/4,168	294/3,074	178mm	146mm	37mm	27mm* or 30mm†	32mm - 75mm	4.20 kg.
<b>IU-7XL</b>	904/9,354	667/6,899	235mm	159mm	38mm	38mm	51mm - 98mm	6.35 kg.
<b>IU-10XL</b>	1,342/13,423	990/9,900	248mm	203mm	50mm	50mm	60mm - 108mm	11.11 kg.
<b>IU-17XL</b>	2,051/21,627	1,513/15,951	286mm	235mm	50mm	62mm	70mm - 137mm	19.05 kg.
<b>IU-25XL</b>	3,064/32,024	2,260/23,620	286mm	235mm	74mm	75mm	89mm - 146mm	25.85 kg.
<b>IU-50XL<sup>§</sup></b>	4,711/60,720	3,475/44,785						

\*32mm to 51mm Heads †56mm to 75mm Heads § Steel Cylinders Only

IU-1XL Heads			IU-3XL Heads			IU-7XL Heads			IU-10XL Heads			IU-17XL Heads			IU-25XL Heads			IU-50XL Heads		
ATF	Radius	P/R	ATF	Radius	P/R	ATF	Radius	P/R	ATF	Radius	P/R	ATF	Radius	P/R	ATF	Radius	P/R	ATF	Radius	P/R
19mm	27mm	10mm	32mm	35mm	9mm	51mm	46mm	12mm	60mm	51mm	11mm	70mm	64mm	23mm	86mm	74mm	24mm	115mm	100mm	33mm
27mm	30mm	9mm	37mm	37mm	9mm	56mm	48mm	12mm	65mm	55mm	12mm	75mm	67mm	23mm	95mm	81mm	26mm	125mm	105mm	33mm
32mm	33mm	9mm	41mm	40mm	9mm	60mm	51mm	12mm	70mm	61mm	14mm	76mm	69mm	25mm	105mm	85mm	25mm	135mm	110mm	33mm
37mm	36mm	9mm	46mm	43mm	10mm	65mm	55mm	12mm	75mm	65mm	13mm	86mm	74mm	25mm	115mm	91mm	25mm	145mm	116mm	32mm
41mm	38mm	9mm	48mm	45mm	12mm	70mm	61mm	14mm	76mm	67mm	16mm	95mm	81mm	26mm	125mm	98mm	25mm	155mm	121mm	32mm
46mm	41mm	9mm	51mm	45mm	10mm	75mm	65mm	13mm	86mm	72mm	24mm	105mm	85mm	26mm	135mm	104mm	26mm	165mm	127mm	32mm
51mm	44mm	9mm	56mm	48mm	10mm	76mm	67mm	16mm	95mm	78mm	24mm	115mm	91mm	26mm	145mm	110mm	28mm	175mm	133mm	32mm
			60mm	50mm	10mm	86mm	72mm	16mm	105mm	83mm	24mm	125mm	99mm	26mm				185mm	138mm	32mm
			65mm	54mm	12mm	95mm	77mm	16mm				135mm	104mm	26mm						
			70mm	57mm	12mm															
			75mm	60mm	12mm															

[www.torqlite.com](http://www.torqlite.com)

### NOTES

1. Maximum load